

FORMOST FUJI

THE FORMOST FFB VARIETY BAGGER

Quality is "First and Formost"



FFB Bagger

**GENTLE,
DEPENDABLE
BAGGING**

POSITIVE PRODUCT CONTROL

QUICK, SIMPLE CHANGEOVER

MAINTAINS PRODUCT QUALITY

GENTLE PRODUCT HANDLING

UP TO 60 BAGS PER MINUTE

PROVEN DEPENDABILITY

The Formost FFB Variety Bagger will automatically bag tortillas to textiles, and buns to hash browns with proper set-up and design. Specially designed paddles move product into the bags with a gentle hand-like motion. Our innovative bag opening system is available to provide for greater tolerance of irregularities.

The FFB Variety Bagger is compact, durable and carefully engineered for trouble-free operation. It will save maintenance costs, too. All parts are readily accessible for easy cleaning and maintenance.

FORMOST FUJI CORPORATION

19211 144th Avenue NE • Woodinville, WA 98072

Phone: 425-483-9090 • Fax: 425-486-5656 • email: salesoffice@formostfuji.com

www.formostfuji.com

Reliable Bagging

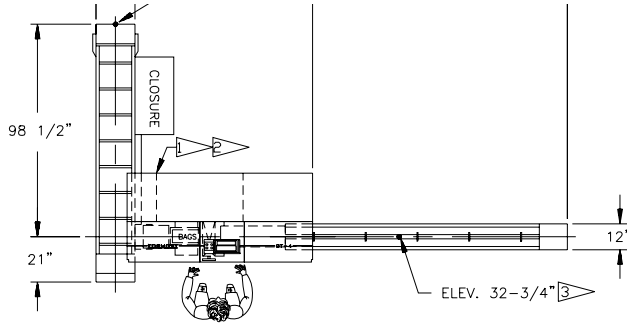

Left-hand variety bagger with rear discharge

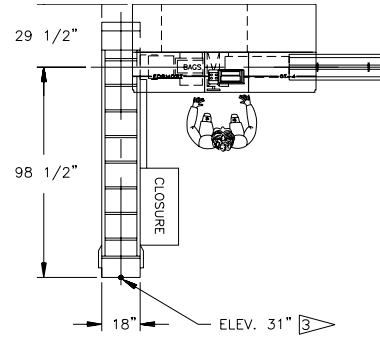

Left-hand variety bagger with front discharge

The Formost FFB is available in several left and right hand configurations.

The bag opening system prepares each bag for product insertion. Different designs are available depending upon the product.



Transfer paddles gently push product through the openers and into the bag, creating a tight bag for best appearance.



After the product is placed in the bag, the bag openers release and product motion separates the bag from the wicket.



Optional Features

- Interfaces for bag closure devices
- Wide product capability
- Front or rear product infeed configuration
- In-line product infeed configuration
- Continuous bag feed
- FO bag openers
- Spare parts kit

FORMOST FUJI FFB VARIETY BAGGER SPECIFICATIONS

LENGTH	86" (2185 mm)	PRODUCT LENGTH	6" (152 mm) to 16" (406 mm)
WIDTH	35" (889 mm)	PRODUCT WIDTH	3" (76 mm) to 8" (203 mm)
HEIGHT	52" (1321 mm)	PRODUCT HEIGHT	2" (51 mm) to 5.5" (140 mm)
WEIGHT	1600 lbs. (727 kg)	BAG LENGTH	10" (254 mm) to 22" (559 mm)
SPEED	20 to 60 ppm	BAG WIDTH	5" (127 mm) to 12" (305 mm)
ELECTRICAL	230/380/460V, 3 phase 50/60 HZ		

These specifications may vary depending on applications. Specifications are based upon the latest information available at the time of publication. Formost reserves the right to make changes in materials, equipment and specifications without prior notice.

FORMOST FUJI CORPORATION

19211 144th Avenue NE • Woodinville, WA 98072

Phone: 425-483-9090 • Fax: 425-486-5656 • email: salesoffice@formostfuji.com